

# MEISTER

ELECTRICAL POWER PRODUCTS, LLC.



## Contents

<b>Types HTC &amp; HTC2</b> .....	5
<b>Double Aluminum Hot Tap Clamps Extruded Type</b> .....	6
Structural Aluminum Alloy .....	6
<b>Type ST</b> .....	7
<b>Aluminum Hot Line Clamp With Copper Pigtail</b> .....	8
<b>Types PT &amp; PTH</b> .....	8
<b>Type PTH</b> .....	9
PTH 250 & 350: .....	9
PTH 500, 750, St 1000: .....	9
Tap Screws above 250 KCM: .....	10
Tap Screws 250 Size and Smaller: .....	10
Clamping Force/Inch Conductor: .....	10
Grease Option: .....	10
<b>Types TT &amp; TTH</b> .....	10
<b>Type TTH</b> .....	11
TTH 250 & 350: .....	11
TTH 500, 750, & 1000: .....	11
Tap Screws above 250 KCM: .....	11
Tap Screws 250 Size and Smaller: .....	11
Clamping Force/Inch Conductor: .....	12
Grease Option: .....	12
<b>Types P2 &amp; P4</b> .....	12
Two Services .....	12
Four Services .....	13
Material Composition: .....	13
Grease Option: .....	13
Clamping Force/Inch Conductor: .....	13
Clamping Force (LBS): .....	13
Screw Details: .....	13
Cover Details: .....	13

**Types T4 & T4H**..... 14

    With Socket Set Screws – 5/16" hex Socket Main – 3/16" Hex Socket Taps..... 14

    With Hex Head Screw - 9/16" Hex Head Main - 7/16" Hex Head Taps..... 15

        Material Composition: ..... 15

        Grease Option:..... 15

        Clamping Force/Inch of Conductor:..... 15

        Clamping Force (LBS): ..... 15

        Cover Details:..... 15

**Type P22** ..... 16

**Type 2PT & 2PTH**..... 17

**TYPE 2PT** - Parallel Tap with 5/16" Hex Socket Set Screws..... 17

**Type 2PTH** ..... 17

    PTH 250 & 350: ..... 18

    PTH 500, 750, & 1000: ..... 18

    Tap Screws above 250 KCM: ..... 18

    Tap Screws 250 Size and Smaller: ..... 18

    Clamping Force/Inch Conductor:..... 18

    Note: ..... 18

    Grease Option:..... 18

**Types BTC & BT90**..... 19

    Material Composition: ..... 20

    Available Options: ..... 20

    Socket Screws:..... 20

    Clamping Force (lbs/inch conductor):..... 20

    Catalog Number Change:..... 20

**Type BTC-H**..... 20

    Material Composition: ..... 21

    Screw Details:..... 21

    Grease Option:..... 21

    Clamping Force (lbs/inch Conductor): ..... 22

**Type BTC-HCB**..... 22

    Material Composition: ..... 23

Bolt Details: ..... 23

Inhibitor Option: ..... 23

Clamping Force/Inch Conductor: ..... 23

**Types SC & BTC1** ..... 24

    Type SC Adapters (in-line) ..... 24

    Type BTC 1 Adapters (offset) ..... 24

        Material Composition: ..... 24

        Clamping Force: ..... 25

        Hex Head Bolts: ..... 25

        Disc Pressure Pads: ..... 25

**Type T4-HDCB** ..... 25

    Single Screw Per Conductor ..... 26

    Double Screw Per Conductor ..... 26

        Material Composition: ..... 26

        Clamping Force: ..... 26

**Types P2A & 2SPA** ..... 26

    One Main Conductor ..... 27

    Two Main Conductors ..... 27

    Four Main Conductors ..... 27

        Screw Options: ..... 27

        Conductor Combinations: ..... 27

        Grease Inhibitor: ..... 27

**Tensioned Conductors:** ..... 28

    The overhead electric system requires a connector that: ..... 28

        Beneficial Properties: ..... 28

        Moisture and Salt Resistance: ..... 28

        Vibration Fatigue: ..... 28

        Screws for Tensioned Conductors: ..... 28

        Screws with Disc Pads (Non-Tension): ..... 29

**Copper to Aluminum Connections:** ..... 29

**Clamping Force and Clamping Force per Inch of Conductor:** ..... 29

Direct Contact Screws (Non-Tension) ..... 29

**Types HTC & HTC2** Aluminum Hot Tap Clamps Extruded Type Structural Aluminum

Catalog Number	Conductor Range AWG or MCM						Weight Perc	Rec. Torque Inch-Lbs.	Main Approx. Clamping Force	Main Clamping Force Lbs. / Inch cond.
	MAIN			TAP						
	MAX		MIN	MAX		MIN.				
	COND.	Inches		Cond.	Inches					
HTC-0	4/0-6/1	0.562	6 SOL	1/0	0.437	6 SOL	40	240	2750	3700
HTC-40	4/0-6/1	0.562	6 SOL	4/0-6/1	0.562	6 SOL	41	240	2750	3700
HTC-560	556.5 ACSR	0.870	2 STR.	2/0	0.437	6 SOL	44	240	2750	3700
HTC-560-40	556.5 ACSR	0.870	2 STR.	4/0-6/1	0.562	6 SOL	46	240	2750	3700
HTC-795	795 ACSR	1.090	336.5	4/0-6/1	0.562	6 SOL	60	240	2750	2750

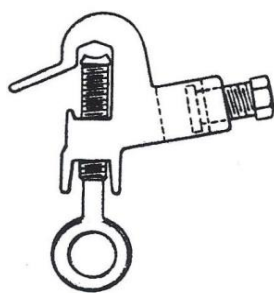

HTC-0  
HTC-40

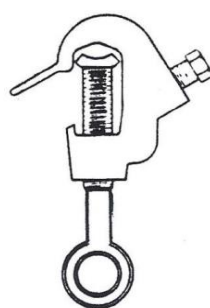

HTC-560

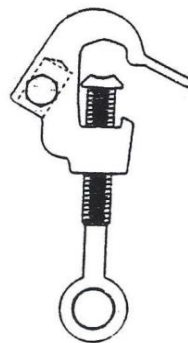

HTC-560-40

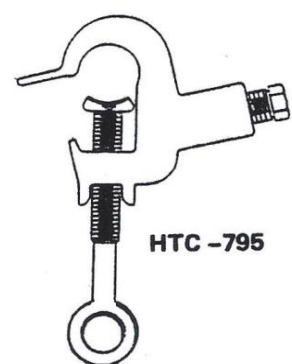

HTC -795

Catalog Number	Conductor Range AWG or MCM						Weight Perc	Rec. Torque Inch-Lbs.	Main Approx. Clamping Force	Main Clamping Force Lbs. / Inch cond.
	MAIN			TAP						
	MAX		MIN	MAX		MIN.				
	COND.	Inches		Cond.	Inches					
HTC2-560	556.5 ACSR	0.870	2 STR.	556.5 ACSR	0.870	2 STR.	128	240	2750	3700
HTC2-795	795 ACSR	1.090	336.5 ACSR	795 ACSR	1.090	2 STR.	166	240	2750	3700

### Double Aluminum Hot Tap Clamps Extruded Type

Structural Aluminum Alloy

*Tap conductor @ 300-inch lbs. torque - Clamping Force approximately 3,000 lbs. each bolt.*

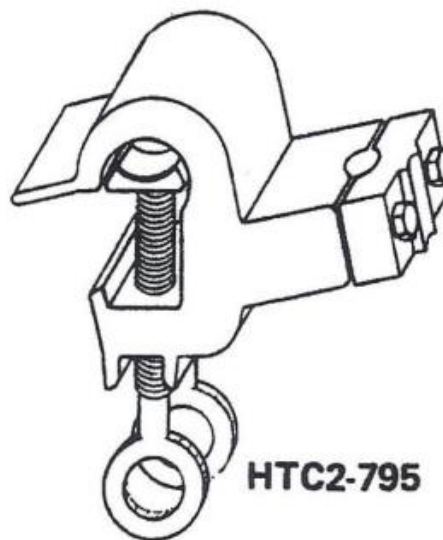
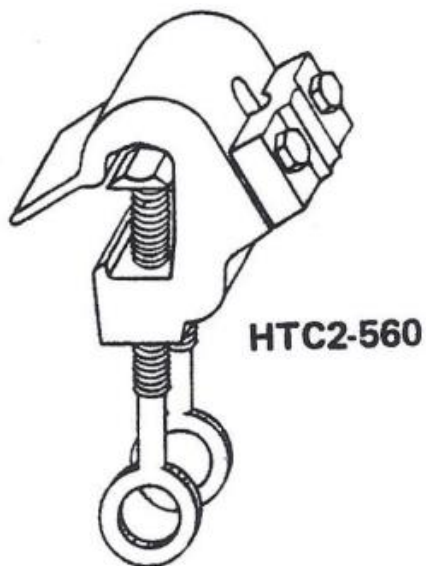

**Type ST** Aluminum Hot Line Stirrup Clamps Extruded Type Structural Aluminum Alloy

Catalog Number	Conductor Range			COPPER BAIL			Weight PERC	Rec. Torque Inch-Lbs.	Clamping Force Lbs.	Clamping Force Lbs / Inch Cond.
	MAX		MIN							
	AWG-KCK	Inches	AWG-KCK	D	W	L				
ST-O	4/0-6/1	0.562	8 SOL	.25	4	4	78	240	2750	3700
ST-40	4/0-6/1	0.562	8 SOL	.3125	4	4	24680	240	2750	3700
ST-560	556.5	0.870	2 STR	.3125	4	4	24082	240	2750	3700
ST-636	636	0.925	STR	.3125	4	4	24086	240	2750	3700
ST795	795	1.090	336.5	.3125	4	4	240105	240	2750	3700

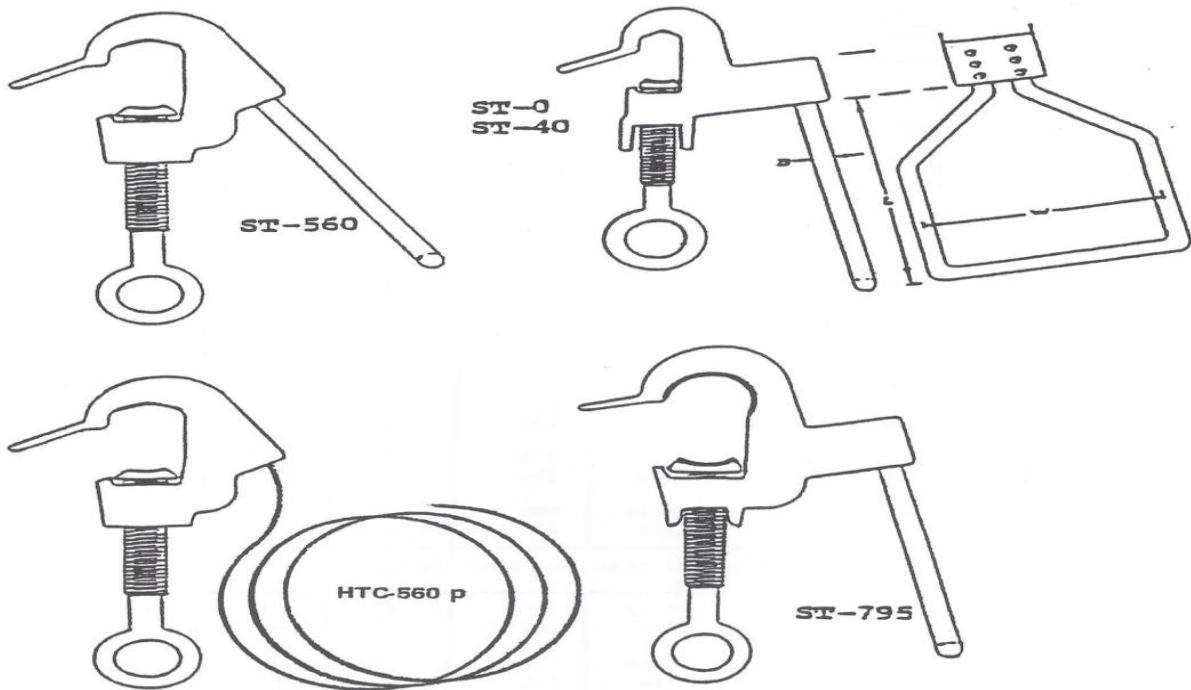

### Aluminum Hot Line Clamp With Copper Pigtail

Catalog Number	CONDUCTOR RANGE			COPPER PIGTAIL		Weight Perc	Inch-Lbs.	Clamping Force	Clamping Force Lbs / Inch Cond.
	MAX		MIN	SIZE	LENGTH				
	AWG-KCK	Inches	AWG-KCK						
HTC-560-6P	4/0-6/1	0.562	8 sol	6 sol	40"	70	240	2750	3700
HTC-560-4P	4/0-6/1	0.562	8 sol	4 sol	40"	82	240	2750	3700

### Types PT & PTH Parallel Tap Connector

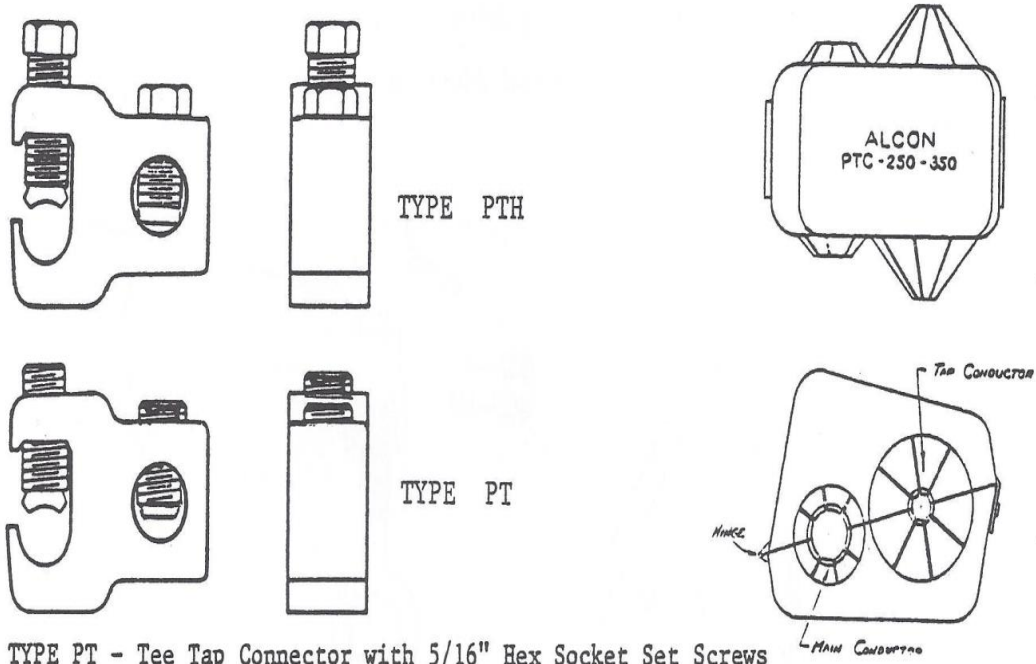



Catalog no.	Conductor Range KCK-AWG		Recommended Torque Inch Lbs.		Clamping Force Lbs / Inch Cond.		Weight Per C
	MAIN	TAP	MAIN	TAP	MAIN	TAP	
PT-250-2/0	250-2	2/0-14	250	200	2500	3500	30
PT-250-250	250-2	250-6	250	250	2500	4000	28
PT-350-2/0	350-2/0	2/0-14	30	200	3000	3500	35
PT-350-350	350-2/0	350-6	300	300	3000	4000	33
PT-500-2/0	2/0-14	2/0-14	350	200	3800	3500	48
PT-500-500	500-2	500-2	350	350	3800	3800	45
PT-750-2/0	2/0-14	2/0-14	400	200	3300	3500	59
PT-750-750	500-2	500-2	400	400	3300	4300	56

**Type PTH - Tee Tap Connector with Hex  
Head Screws**

Catalog no.	Conductor Range KCK-AWG		Recommended Torque Inch / Lbs.		Clamping Force Lbs / Inch Cond.		Weight Per C
	MAIN	TAP	MAIN	TAP	MAIN	TAP	
PTH-250-2/0	250-2	2/0-14	250	200	2500	3500	32
PTH-250-250	250-2	250-6	250	250	2500	4000	30
PTH-350-2/0	350-2/0	2/0-14	300	200	3000	3500	37
PTH-350-350	350-2/0	250-6	300	300	3000	4000	35
PTH-500-2/0	500-250	2/0-14	350	200	3800	3500	50
PTH-500-500	500-250	500-2	350	350	3800	4000	48
PTH-750-2/0	750-500	2/0-14	400	200	3300	3500	63
PTH-750-750	750-500	750-4/0	400	400	3300	4300	60
PTH-1000-2/0	1000-500	2/0-14	450	200	3700	3500	74
PTH-1000-750	1000-500	750-4/0	450	450	3700	5600	70

PTH 250 & 350:

- Size: PTH 250 and 350
- Hex Head: 9/16"
- Main & Tap: Hex Head

PTH 500, 750, St 1000:

- Size: PTH 500, 750, St 1000

- Hex Head: 3/4"
- Main & Tap: Hex Head

Tap Screws above 250 KCM:

- Feature: Disc Pressure Pads

Tap Screws 250 Size and Smaller:

- Feature: Flat Bottom Tap Screw

Clamping Force/Inch Conductor:

- Calculation: Approximate value based on recommended Torque applied by the Screw or Pressure Pad.

Grease Option:

- Suffix: Add "G" for Grease.

## Types TT & TTH Tee Tap Connector

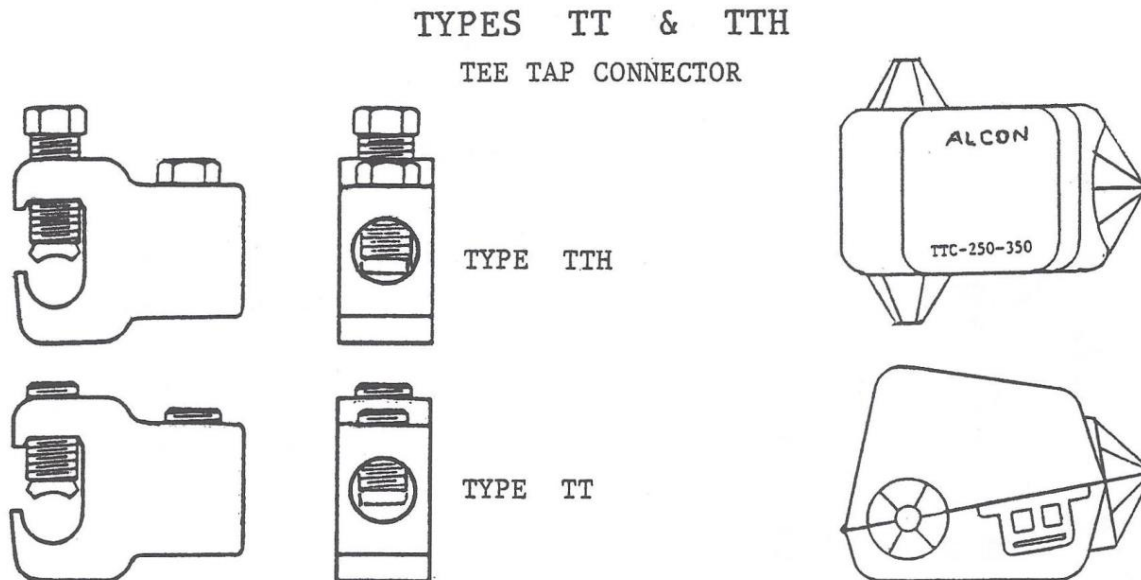

TYPE TT - Tee Tap Connector with 5/16" Hex Socket Set Screws

Catalog no.	Conductor Range KCK-AWG		Recommended Torque Inch / Lbs.		Clamping Force Lbs / Inch Cond.		Weight Per C
	MAIN	TAP	MAIN	TAP	MAIN	TAP	

TT-250-2/0	250-2	2/0-14	250	200	2500	3500	30
TT-250-250	250-2	250-6	250	250	2500	4000	28
TT-350-2/0	350-2/0	2/0-14	300	200	3000	3500	35
TT-350-350	350-2/0	350-6	300	300	3000	4000	33
TT-500-2/0	500-250	2/0-14	350	200	3800	3500	48
TT-500-500	500-250	500-2	350	350	3800	4000	45
TT-750-2/0	750-500	2/0-14	400	200	3300	3500	59
TT-750-750	750-500	500-2	400	400	3300	4300	56

### Type TTH - Tee Tap Connector with Hex Head Screws

Catalog no.	Conductor Range KCK-AWG		Recommended Torque Inch / Lbs.		Clamping Force Lbs / Inch Cond.		Weight Per C
	MAIN	TAP	MAIN	TAP	MAIN	TAP	
TTH-250-2/0	250-2	2/0-14	250	200	2500	3500	32
TTH-250-250	250-2	250-6	250	250	2500	4000	30
TTH-350-2/0	350-2/0	2/0-14	300	200	3000	3500	37
TTH-350-350	350-2/0	250-6	300	300	3000	4000	35
TTH-500-2/0	500-250	2/0-14	350	200	3800	3500	50
TTH-500-500	500-250	500-2	350	350	3800	4000	48
TTH-750-2/0	750-500	2/0-14	400	200	3300	3500	63
TTH-750-750	750-500	750-4/0	400	400	3300	4300	60
TTH-1000-2/0	1000-500	2/0-14	450	200	3700	3500	74
TTH-1000-750	1000-500	750-4/0	450	450	3700	5600	70

#### TTH 250 & 350:

- Size: TTH 250 and 350
- Hex Head: 9/16"
- Main & Tap: Hex Head

#### TTH 500, 750, & 1000:

- Size: TTH 500, 750, and 1000
- Hex Head: 3/4"
- Main & Tap: Hex Head

#### Tap Screws above 250 KCM:

- Feature: Disc Pressure Pads

#### Tap Screws 250 Size and Smaller:

- Feature: Flat Bottom Tap Screw

Clamping Force/Inch Conductor:

- Calculation: Approximate value at recommended Torque applied by the Screw or Pressure Pad.

Grease Option:

- Suffix: Add "G" for Grease.

### Types P2 & P4 Multiple Parallel Connector

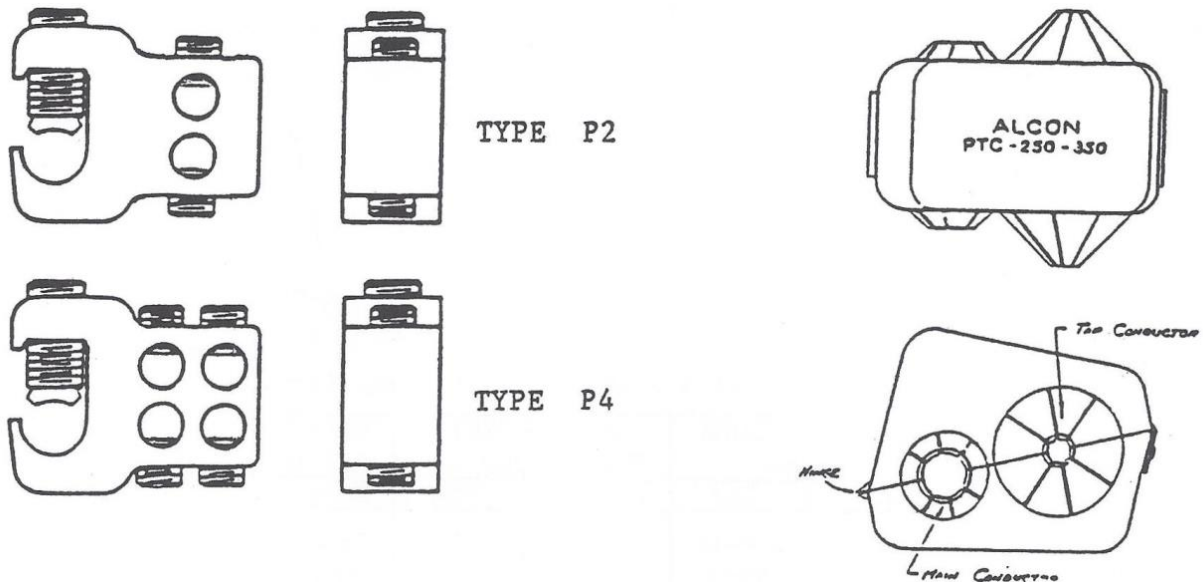

Two Services

Catalog No.	Main Range	Services		Catalog Cover No.	Torque Inch / Lbs		Clamping Force Lbs/Inch Cond.	
		Number	Size		Main	Tap	Main	Tap
P2-250/10	250-2	2	1/0-14	PTC-250-350	250	150	2500	4200
P2-250-2/0	250-2	2	2/0-14	PTC-250-350	250	150	2500	4200
P2-250-3/0	250-2	2	3/0-14	PTC-250-350	250	150	2500	4200
P2-350-1/0	250-2	2	1/0-14	PTC-250-350	300	150	3000	4200
P2-350-2/0	350-2	2	2/0-14	PTC-250-350	300	150	3000	4200
P2-350-3/0	350-2	2	3/0-14	PTC-250-350	300	150	3000	4200

P2-500-2/0	500-250	2	2/0-14	PTC-500-500	350	150	3800	4200
------------	---------	---	--------	-------------	-----	-----	------	------

## Four Services

Catalog No.	Main Range	Services		Catalog Cover No.	Torque Inch / Lbs		Clamping Force Lbs/Inch Cond.	
		Number	Size		Main	Tap	Main	Tap
P2-250/10	250-2	2	1/0-14	PTC-250-350	250	150	2500	4200
P2-250-2/0	250-2	2	2/0-14	PTC-250-350	250	150	2500	4200
P2-250-3/0	250-2	2	3/0-14	PTC-250-350	250	150	2500	4200
P2-350-1/0	250-2	2	1/0-14	PTC-250-350	300	150	3000	4200
P2-350-2/0	350-2	2	2/0-14	PTC-250-350	300	150	3000	4200
P2-350-3/0	350-2	2	3/0-14	PTC-250-350	300	150	3000	4200
P2-500-2/0	500-250	2	2/0-14	PTC-500-500	350	150	3800	4200

## Material Composition:

- Body: Fabricated from 6061-T6 Aluminum
- Screw Alloy: 6262-T9

## Grease Option:

- Suffix: Add "G" for Grease.

## Clamping Force/Inch Conductor:

- Calculation: Approximate value at recommended Torque values applied by the Screw or Pressure Pad.

## Clamping Force (LBS):

- Clamping Force/Inch - Of Pressure Device

## Screw Details:

- Main Screw:
  - Hex Socket Size: 5/16"
- Tap Screws:
  - Hex Socket Size: 3/16"

## Cover Details:

- PTC-250-350:
  - Material: Molded from Black Polyethylene
- PTC-500-500:
  - Material: Molded from Black PVC

### Types T4 & T4H Multiple Tee Tap Connector

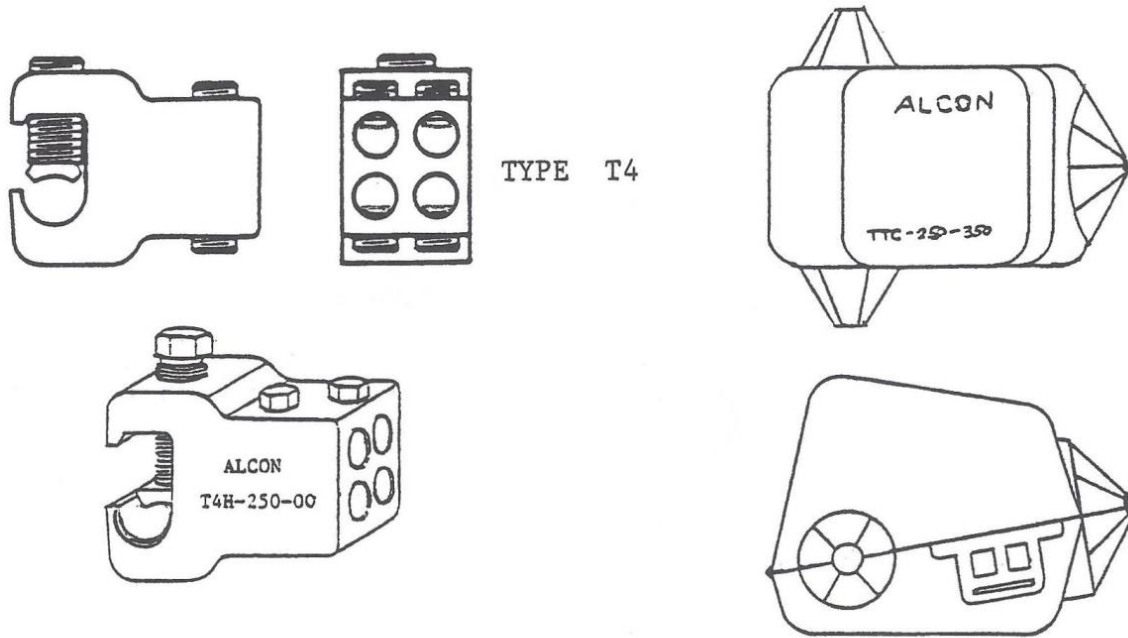

With Socket Set Screws - 5/16" Hex Socket Main - 3/16" Hex Socket Taps

With Socket Set Screws - 5/16" hex Socket Main - 3/16" Hex Socket Taps

Catalog No.	Main Range	Services		Catalog Cover No.	Torque Inch / Lbs		Clamping Force Lbs/Inch Cond.	
		Number	Size		Main	Tap	Main	Tap
T4-250-1/0	250-2	4	1/0-14	TTC-250-350	250	150	2500	4200
T4-250-2/0	250-2	4	2/0-14	TTC-250-350	250	150	2500	4200
T4-350-1/0	350-2/0	4	1/0-14	TTC-250-350	250	150	2500	4200
T4-350-2/0	350-2/0	4	2/0-14	TTC-250-350	300	150	3000	4200
T4-500-1/0	500-250	4	1/0-14		300	150	3000	4200
T4-500-2/0	500-250	4	2/0-14		300	150	3000	4200

With Hex Head Screw - 9/16" Hex Head Main - 7/16" Hex Head Taps

Catalog No.	Main Range	Services		Catalog Cover No.	Torque Inch / Lbs		Clamping Force Lbs/Inch Cond.	
		Number	Size		Main	Tap	Main	Tap
T4-250-1/0	250-2	4	1/0-14	TTC-250-350	250	150	2500	4200
T4-250-2/0	250-2	4	2/0-14	TTC-250-350	250	150	2500	4200
T4-350-1/0	350-2/0	4	1/0-14	TTC-250-350	250	150	2500	4200
T4-350-2/0	350-2/0	4	2/0-14	TTC-250-350	300	150	3000	4200
T4-500-1/0	500-250	4	1/0-14		300	150	3000	4200
T4-500-2/0	500-250	4	2/0-14		300	150	3000	4200

Material Composition:

- Body: Fabricated from 6061-T6 Aluminum
- Screw Alloy: 6262-T9

Grease Option:

- Suffix: Add "G" for Grease.

Clamping Force/Inch of Conductor:

- Calculation: Approximate value at recommended Torque values applied by the Screw or Pressure Pad.

Clamping Force (LBS):

- Clamping Force/Inch
- Length of Pressure Device

Cover Details:

- TTC-250-350:
  - Material: Molded from Black Polyethylene

## Type P22 Multiple Parallel Connector

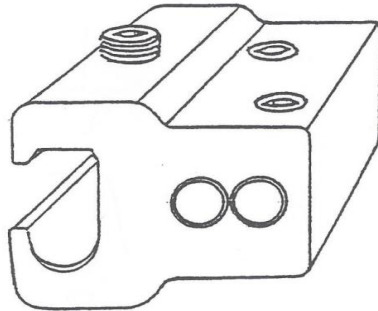

TERMINAL: 6061-T6 Body  
6262-T9 Screws  
With 5/16" Hex Sockets

COVER: P22-250-00  
BLACK POLYETHYLENE

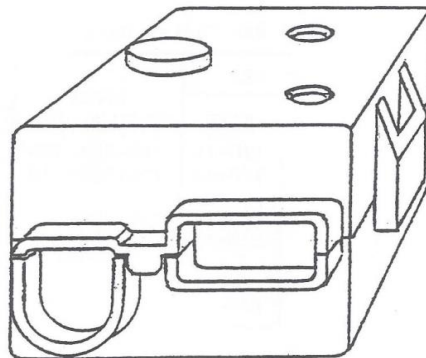

Catalog no.	Conductor Range		Weight Per C with Cover	Torque Inch / Lbs		Clamping force Lbs / Inch cond.	
	Main	Services		Main	Services	Main	Service
P22-250-00	250-2	2/0-14	78	250	200	2500	3500
P22-250-3/0	250-2	3/0-14	76	250	200	2500	3500



## Type 2PT & 2PTH Heavy Duty Parallel Connector

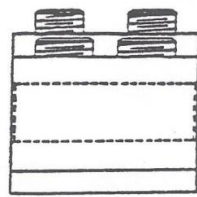
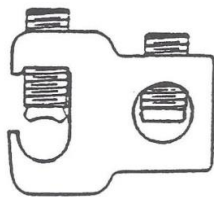

TYPE 2PT

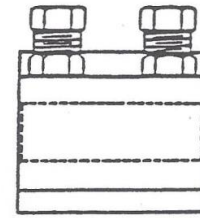
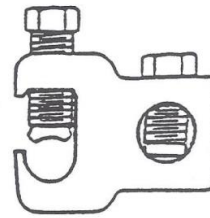

TYPE 2PTH

### TYPE 2PT - Parallel Tap with 5/16" Hex Socket Set Screws

Catalog no.	Conductor Range KCK-AWG		Recommended Torque Inch / Lbs.		Clamping Force Lbs / Inch Cond.		Weight Per C
	MAIN	TAP	MAIN	TAP	MAIN	TAP	
2PT-250-250	250-2	250-6	250	250	2500	4000	55
2PT-350-350	350-2/0	350-6	300	300	3000	4000	62
2PT-500-500	500-250	500-2	350	350	3800	4300	110
2PT-750-500	750-500	500-2	400	400	3300	5000	150
2PT-750-750	750-500	750-4/0	400	400	3300	5000	148
2PT-1000-500	1000-500	500-2	450	450	3700	5600	175
2PT-1000-1000	1000-500	1000-500	450	450	3700	5600	170

### Type 2PTH - Parallel Tap with Hex Head Set Screw

Catalog no.	Conductor Range KCK-AWG		Recommended Torque Inch / Lbs.		Clamping Force Lbs / Inch Cond.		Weight Per C
	MAIN	TAP	MAIN	TAP	MAIN	TAP	
2PT-250-250	250-2	250-6	250	250	2500	4000	55
2PT-350-350	350-2/0	350-6	300	300	3000	4000	62
2PT-500-500	500-250	500-2	350	350	3800	4300	110
2PT-750-500	750-500	500-2	400	400	3300	5000	150
2PT-750-750	750-500	750-4/0	400	400	3300	5000	148
2PT-1000-500	1000-500	500-2	450	450	3700	5600	175
2PT-1000-1000	1000-500	1000-500	450	450	3700	5600	170

PTH 250 & 350:

- Quantity: 2
- Size: PTH 250 and 350
- Hex Head: 9/16"
- Main & Tap: Hex Head

PTH 500, 750, & 1000:

- Quantity: 2
- Size: PTH 500, 750, and 1000
- Hex Head: 3/4"
- Main & Tap: Hex Head

Tap Screws above 250 KCM:

- Feature: Disc Pressure Pads

Tap Screws 250 Size and Smaller:

- Feature: Flat Bottom Screws

Clamping Force/Inch Conductor:

- Calculation: Approximate value at recommended Torque applied by the screw or pressure pad.

Note:

- Double screws per conductor provide two current paths, each with the Clamping Force/Inch Conductor shown above.

Grease Option:

- Suffix: Add "G" for Grease.

**Types BTC & BT90** Aluminum Multiple Terminals Aluminum & Copper Conductors  
**(For use with copper alloy Eye-Bolt Terminals)**

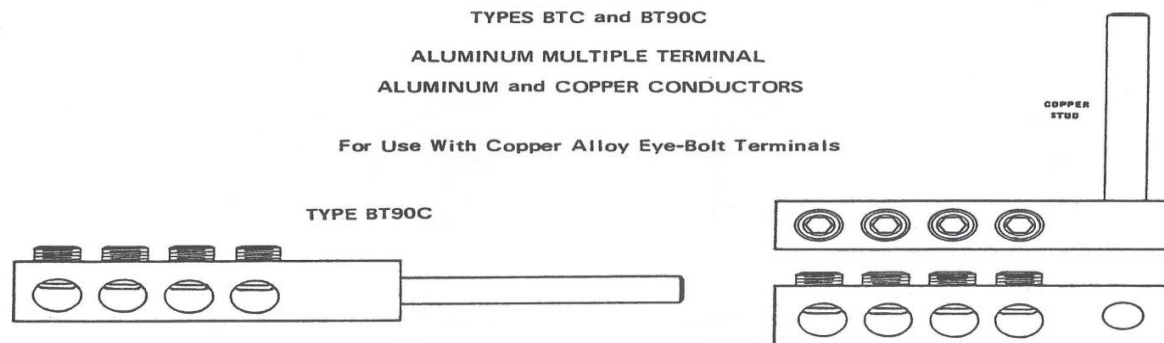

Catalog No.	No. of Conds.	Cond. Range	Copper Stud		Weight Per C	Screw Size	Torque lbs/inch	Clamping force lbs/inch
			Dia.	Length				
BTC2-250	2	250-6	0.500	4	50	5/8-18	300	3330 Rnd. Bottom 3330 Flat Bottom 5450 Disk PP
BTC3-250	3	250-6	0.500	4	56	5/8-18	300	
BTC4-250	4	250-6	0.500	4	62	5/8-18	300	
BTC5-250	5	250-6	0.500	4	68	5/8-18	300	
BTC6-250	6	250-6	0.500	4	74	5/8-18	300	
BTC8-250	8	250-6	0.500	4	86	5/8-18	300	
BTC2-350	2	350-6	0.500	4	81	5/8-18	300	3330 Rnd. Bottom 3330 Flat Bottom 5450 Disk PP
BTC3-350	3	350-6	0.500	4	89	5/8-18	300	
BTC4-350	4	350-6	0.500	4	97	5/8-18	300	
BTC5-350	5	350-6	0.500	4	105	5/8-18	300	
BTC6-350	6	350-6	0.500	4	113	5/8-18	300	
BTC8-350	8	350-6	0.500	4	129	5/8-18	300	
BTC2-500	2	500-2	0.750	4.5	123	5/8-18	300	3330 Rnd. Bottom 3330 Flat Bottom 5450 Disk PP
BTC3-500	3	500-2	0.750	4.5	134	3/4-16	350	
BTC4-500	4	500-2	0.750	4.5	146	11/16-16	350	
BTC5-500	5	500-2	0.750	4.5	158	11/16-16	350	
BTC6-500	6	500-2	0.750	4.5	170	11/16-16	350	
BTC8-500	8	500-2	0.750	4.5	193	11/16-16	350	
BTC2-750	2	500-2	0.750	4.5	140	11/16-16	350	3330 Rnd. Bottom 3330 Flat Bottom 5450 Disk PP
BTC3-750	3	500-2	0.750	4.5	157	15/16-16	350	
BTC4-750	4	500-2	0.750	4.5	175	15/16-16	480	
BTC5-750	5	500-2	0.750	4.5	192	3/4-16	480	
BTC6-750	6	500-2	0.750	4.5	209	3/4-16	480	
BTC8-750	8	500-2	0.750	4.5	244	3/4-16	480	

## Material Composition:

- Body: Fabricated from 6061-T6 Aluminum
- Screw Alloy: 6262-T9

## Available Options:

- Round Bottom Screws: Add Suffix "RB"
- Flat Bottom Screws: Add Suffix "F"
- Disc Pressure Pads: Add Suffix "D"

## Socket Screws:

- Hex Wrench Socket Size: 5/16"

## Clamping Force (lbs/inch conductor):

- Calculation: Approximate value at recommended torques, applied by screw or pressure pad.

## Catalog Number Change:

- For the BT90C Terminal, change the catalog number from BTC to BT90C.

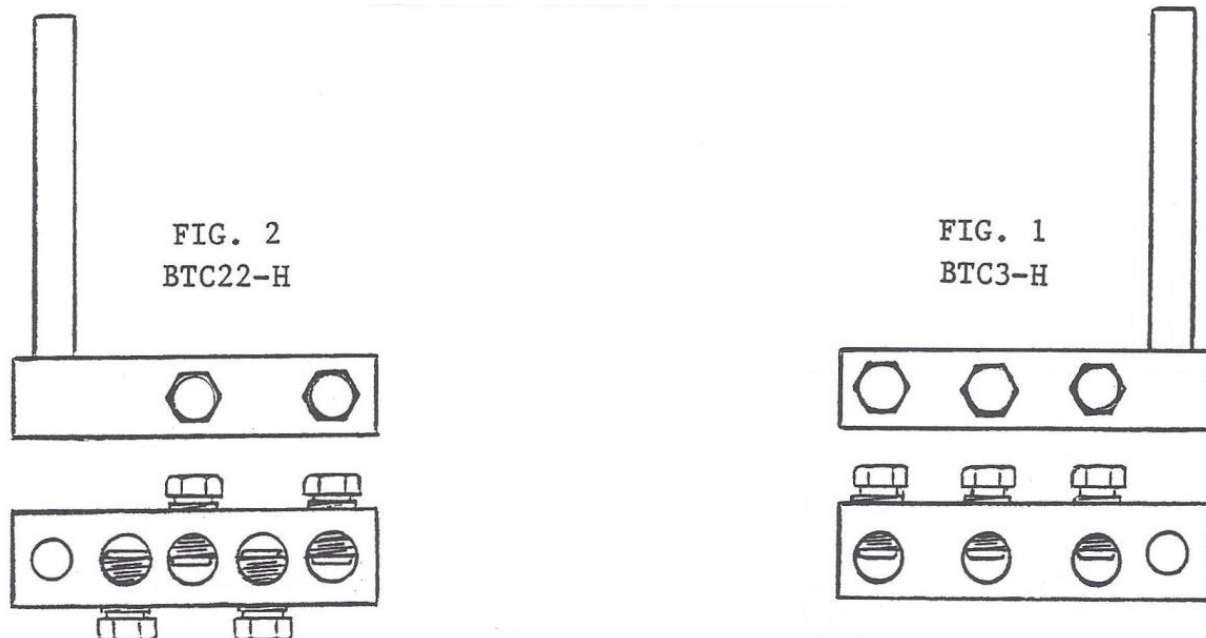
**Type BTC-H** Stud Terminal Hex Head Wrench Tightening

Catalog No.	FIG.	No. of Cond.	Cond. Range	Length	Copper Stud		Screw Size	Clamping Force Lbs / Inch
					Dia.	Length		
BTC2-250-H	1	2	250-6	3.2	0.500	4	9/16-18	6400
BTC3-250-H	1	3	250-6	4.5	0.500	4	9/16-18	6400
BTC22-250-H	2	4	250-6	4.3	0.500	4	9/16-18	6400
BTC33-250-H	2	6	250-6	6.0	0.500	4	9/16-18	6400
BTC2-350-H	1	2	350-6	3.4	0.500	4	5/8-18	4900
BTC3-350-H	1	3	350-6	5.7	0.500	4	5/8-18	4900
BTC22-350-H	2	4	350-6	4.8	0.500	4	5/8-18	4900
BTC33-350-H	2	6	350-6	6.7	0.500	4	5/8-18	4900
BTC2-500-HD	1	2	500-2	4.1	0.750	4.5	3/4-16	5330
BTC3-500-HD	1	3	500-2	5.7	0.750	4.5	3/4-16	5330
BTC22-500-HD	2	4	500-2	6.4	0.750	4.5	3/4-16	5330
BTC33-500-HD	2	6	500-2	8.1	0.750	4.5	3/4-16	5330
BTC2-750-HD	1	2	750-1/0	4.9	0.750	4.5	3/4-16	5330
BTC3-750-HD	1	3	750-1/0	6.7	0.750	4.5	3/4-16	5330
BTC22-750-HD	2	4	750-1/0	7.0	0.750	4.5	3/4-16	5330

#### Material Composition:

- Body: Fabricated from 6061-T6 Aluminum
- Screw Alloy: 6262-T9

#### Screw Details:

- 9/16—13 Screws:
  - Type: Flat Bottom
  - Wrench Size: 9/16"
  - Torque: 30 F.P.
- 5/8-18 Screws:
  - Type: Disc Pads only
  - Wrench Size: 5/8"
  - Torque: 30 F.P.
- 3/4-16 Screws:
  - Type: Disc Pads only
  - Wrench Size: 3/4"
  - Torque: 40 F.P.

#### Grease Option:

- Suffix: Add "G" for Grease.

Clamping Force (lbs/inch Conductor):

- Calculation: Approximate value at recommended torque value, applied by the end of the screw or pressure pad.

**Type BTC-HCB** Stud Terminal Hex Head For Wrench Tightening Counter Bored To Recess Conductor Insulation

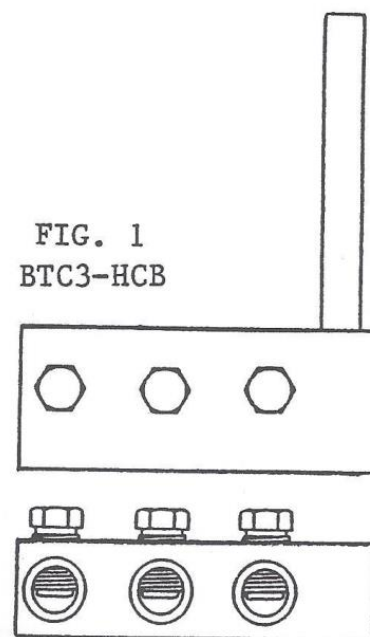
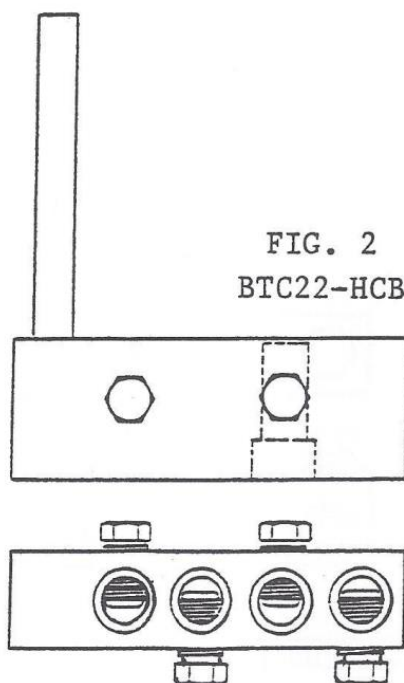

Catalog No.	FIG.	No. of Cond.	Cond. Range	Length	Copper Stud		Bolt Size	Clamping Force Lbs / Inch
					Dia.	Length		
BTC2-250-HCB	1	2	250-6	3.2	0.500	4	9/16-18	6400
BTC3-250-HCB	1	3	250-6	4.5	0.500	4	9/16-18	6400
BTC22-250-HCB	2	4	250-6	4.3	0.500	4	9/16-18	6400
BTC33-250-HCB	2	6	250-6	6.0	0.500	4	9/16-18	6400
BTC2-350-HCB	1	2	350-6	3.4	0.500	4	5/8-18	4900
BTC3-350-HDCB	1	3	350-6	5.7	0.500	4	5/8-18	4900
BTC22-350-HDCB	2	4	350-6	4.8	0.500	4	5/8-18	4900
BTC33-350-HDCB	2	6	350-6	6.7	0.500	4	5/8-18	4900
BTC2-500-HDCB	1	2	500-2	4.1	0.750	4.5	3/4-16	5330

BTC3-500-HDCB	1	3	500-2	5.7	0.750	4.5	3/4-16	5330
BTC22-500-HDCB	2	4	500-2	6.4	0.750	4.5	3/4-16	5330
BTC2-750-HDCB	1	2	750-1/0	4.9	0.750	4.5	3/4-16	5330
BTC22-750-HDCB	2	4	750-1/0	7.0	0.750	4.5	3/4-16	5330

## Material Composition:

- Body: Fabricated from 6061-T6 Aluminum
- Screw Alloy: 6262-T9

## Bolt Details:

- 9/16-18 Bolts:
  - Type: Flat Bottom
  - Wrench Size: 9/16"
  - Torque: 30 F.P.
- 5/8-18 Bolts:
  - Type: Disc Pads only
  - Wrench Size: 5/8"
  - Torque: 30 F.P.
- 3/4-16 Bolts:
  - Type: Disc Pads only
  - Wrench Size: 3/4"
  - Torque: 40 F.P.

## Inhibitor Option:

- Suffix: Add "G" for Inhibitor.

## Clamping Force/Inch Conductor:

- Calculation: At recommended torque value.

## Types SC & BTC1 Adapters Heavy Duty Service Terminals Copper Stud To Aluminum Conductor



FIG. 1  
TYPE SC

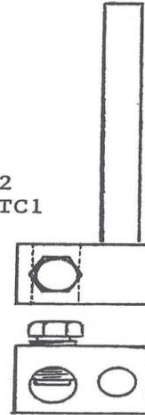

FIG. 2  
TYPE BTC1

### Type SC Adapters (in-line)

Catalog No.	FIG	Cond. Range	Torque	Copper Stud		Bolt Size	Clamping Force Lbs / Inch
				Dia.	Length		
SC-5/16-2/0-H	1	2/0-8	200	5/16	2.3	1/2-20	4000
SC-3/8-4/0-H	1	4/0-6	250	3/8	3.0	9/16-18	4400
SC-1/2-250-H	1	250-6	300	1/2	4.0	9/16-18	5300
SC-1/2-350-H	1	350-6	350	1/2	4.0	5/8-18	4800
SC3/4-500-H	1	500-2	480	3/4	4.5	3/4-16	5330
SC-3/4-750-H	1	750-1/0	480	3/4	4.5	3/4-16	5330

### Type BTC 1 Adapters (offset)

Catalog No.	FIG	Cond. Range	Torque	Copper Stud		Bolt Size	Clamping Force Lbs / Inch
				Dia.	Length		
BTC1-250-H	2	250-6	300	1/2	4.0	9/16-18	5300
BTC1-350-H	2	350-6	350	1/2	4.0	5/8-18	4800
BTC1-500-H	2	500-2	480	3/4	4.5	3/4-16	5330
BTC1-750-H	2	750-1/0	480	3/4	4.5	3/4-16	5330

#### Material Composition:

- Body: Fabricated from 6061-T6 Aluminum



- Screw Alloy: 6262-T9

Clamping Force:

- Calculation: Approximate values at recommended torque.

Hex Head Bolts:

- Type: Flat Bottom
- Sizes: 1/2" thru 5/8" diameter

Disc Pressure Pads:

- Available only with 3/4" diameter bolts.

---

**Type T4-HDCB** Aluminum Lug Terminals for Transformers – 167 KVA and Larger, Hex Head & Counter-Bored

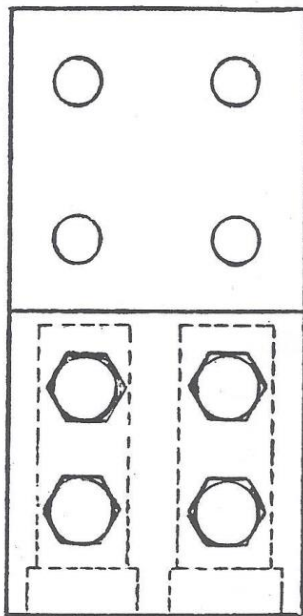

FIG. 2  
DOUBLE SCREW

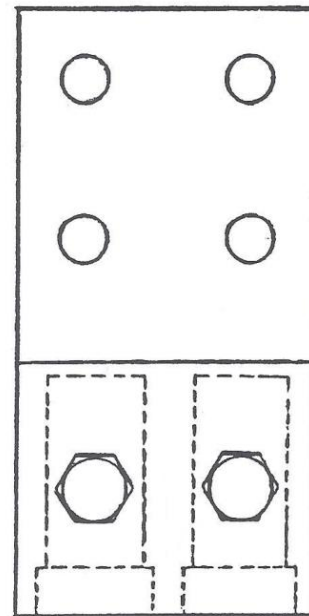

FIG. 1  
SINGLE SCREW

## Single Screw Per Conductor

Catalog No.	FIG	Torque	Conductor Range		Bolt Size	Clamping Force Lbs / Inch
			No.	KCK-AWG		
T4G2-500-HDCB	1	480	2	500-2	3/4-16	5330
T6G3-500-HDCB	1	480	3	500-2	3/4-16	5330
T4G2-750-HDCB	1	480	2	750-1/0	3/4-16	5330
T6G3-750-HDCB	1	480	3	750-1/0	3/4-16	5330

## Double Screw Per Conductor

Catalog No.	FIG	Torque	Conductor Range		Bolt Size	Clamping Force Lbs / Inch
			No.	KCK-AWG		
T4G22-500-HDCB	2	480	2	500-2	3/4-16	5330
T6G33-500-HDCB	2	480	3	500-2	3/4-16	5330
T4G22-750-HDCB	2	480	2	750-1/0	3/4-16	5330
T6G33-750-HDCB	2	480	3	750-1/0	3/4-16	5330

## Material Composition:

- Body: Fabricated from 6061-T6 Aluminum
- Screw Alloy: 6262-T9

## Clamping Force:

- Approximate values: lbs. per inch of conductor for each bolt.

## Types P2A &amp; 2SPA Heavy Duty Service Connectors

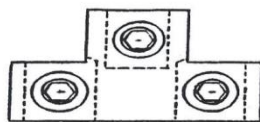

FIG. 1

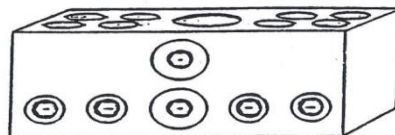

FIG. 2

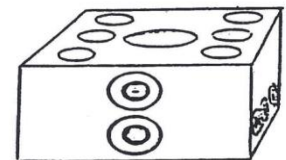

FIG. 3

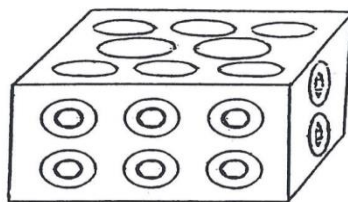

FIG. 4

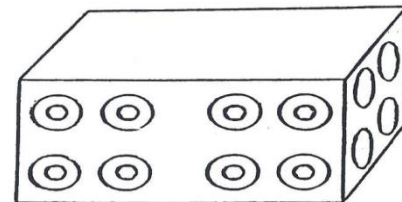

FIG. 5

## One Main Conductor

Catalog No.	Fig.	MAINS		SERVICE	
		No.	Range	No.	Range
P2A12-350-500	1	1	350-6	2	500-2
P2A14-750-350	2	1	750-1/0	4	350-6
P2A18-750-250	2	1	750-1/0	8	250-6
P2A16-750-250	3	1	750-1/0	6	250-6

## Two Main Conductors

Catalog No.	Fig.	MAINS		SERVICE	
		No.	Range	No.	Range
P2A24-500-350	3	2	500-2	4	350-6
P2A26-1000-250	3	2	1000-250	6	250-6
2PA26-750-250	4	2	750-1/0	6	500-2
2PA24-1000-500	4	2	1000-250	4	500-2

## Four Main Conductors

Catalog No.	Fig.	MAINS		SERVICE	
		No.	Range	No.	Range
2SPA44-750-750	5	4	750-1/0	4	750-1/0

## Screw Options:

- Suffix "RB": Round Bottom
- Suffix "FB": Flat Bottom
- Suffix "Disc": Disc

## Conductor Combinations:

- Other combinations available - consult factory.

## Grease Inhibitor:

- Add "G" for Grease Inhibitor.

**For inquiries regarding alternative combinations or specific requirements, we invite you to reach out to Alcon Connectors at your earliest convenience. Our dedicated team is ready to provide professional assistance and address any unique needs you may have. Please feel free to contact us at (513) 722-1037, and we look forward to serving you with our expertise and tailored solutions.**

**Tensioned Conductors:**

The overhead electric system requires a connector that:

- Is not affected by moisture in the form of rain or condensation.
- Should resist the influence of airborne salt in salty areas or along salted highways.
- Will not contribute to vibration fatigue of the conductor.

**Beneficial Properties:**

- a. Almost twice the typical Yield Strength of cast aluminum and more than twice the Yield Strength of cast silicon Bronze.
- b. Light in weight, approximately one-third the weight of cast silicon Bronze and Steel.
- c. A low modulus of elasticity makes it 1.8 times more elastic than copper alloys and three times more elastic than steel at any stress level in the elastic range.

**Moisture and Salt Resistance:**

- The function of clamping force per inch of conductor.
- Clamps with at least 2500 lbs. per inch of conductor effectively could flow the strands to close-up crevices where moisture or salt can collect.

**Vibration Fatigue:**

- Occurs primarily at points of support or a clamp located on a tension line.
- Importance of cold flowing the conductor uniformly without nicking any strands.
- A curved pressure pad conforming to the round conductor is necessary for uniform clamping force without abrading the conductor.

**Screws for Tensioned Conductors:**

Screw with Curved Pad	Rec. Torque	Clamping Force Lbs./inch
-----------------------	-------------	--------------------------

1/2-13	240	2750-3660
3/4-18	300	3000
3/4-16	400	3000-4000

#### Screws with Disc Pads (Non-Tension):

Screw with Disc Pad	Rec. Torque	Clamping Force Lbs./inch
5/8-18	300	3900
11/16-16	350	4200
3/4-16	480	5200
13/16-16	480	5000
15/16-16	480	4250

#### Copper to Aluminum Connections:

- Best made at the factory for uniform bright metal contact and high clamping force.
- Copper stud designs with press-fit of H.D. copper stud into 6061-T6 aluminum body.
- Pin terminals utilizing a soft aluminum crimp tube are not fundamentally sound.

#### Clamping Force and Clamping Force per Inch of Conductor:

- Parameters for the life of a bolted connection.
- Chart lists parameters for various screw sizes:

#### Direct Contact Screws (Non-Tension)

Screw with Curved Pad	Rec. Torque	Clamping Force Lbs./inch
9/16-18	250	20000
5/8-18	300	1750-1900
11/16-16	350	1900-2000
3/4-16	350	1800-2000
13/16-16	350	1750-2000
15/16-16	350	1700-1800

\* Limited by Conductor Damage.